

DOCUMENT TECHNIQUE D'APPLICATION

(English version)

U Block & Corner Block



Bâtir pour la vie

Introduction

The United Basalt Products Ltd. has recently introduced on the Mauritian market a range of complementary blocks under the label SMART BLOCKS in order to complete its range of conventional blocks.

We are referring here to U Blocks and Corner Blocks.

The aim of the UBP is to supply to the Mauritian Building Industry, two types of blocks, which are commonly used worldwide since decades and have proved themselves economical, ecological, and easy to use.

These two blocks when used concurrently with the standard blocks will substantially reduce the use of traditional shuttering which is expensive, labour intensive and time consuming for our local housing projects.

U blocks are used to create horizontal ties at the top of load bearing block work and also to form lintols over doors and windows. In addition, they can also be very useful to form window sills.

Corner blocks are used to create vertical ties in both projecting and recessed angles. They are also used to form jambs at openings, doors & windows, and will contribute positively in the overall stability of the building.

A study has been carried out by the University of Mauritius in order to confirm the added value and sustainability of these blocks.

(See conclusion of the report at the end of the brochure)

The Purpose of Horizontal and Vertical Ties (Translated extract of the DTU 20.1)

The reinforcing within the blocks acts essentially as TIES resisting to tension in those elements. The role of the surrounding concrete is to ensure a good protection against corrosion and the bonding of the overlapping bars together to create continuity and to properly link all the ties together. The minimum section of concrete required, allowing an easy placing of the concrete, is either a square cell having a side of 100mm or a diameter of 100mm, which is INFERIOR to what would have been required in a frame structure, with which a tie MUST NOT BE COMPARED.

Reference Documents

- | | |
|--|--|
| • DTU 20.1 OCT. 2008 | Refer to the website of AFNOR: https://www.boutique.afnor.org |
| • 'Guide d'utilisation UBP' - U Block & Corner Block | Refer to the website of UBP: www.ubp.mu |
| • Specification Sheet - U Block & Corner Block | Refer to the website of UBP: ww.ubp.mu |
| • Specification Sheet - Block 20.15 | Refer to the website of UBP: ww.ubp.mu |
| • Report of the University of Mauritius | Refer to the website of UBP: ww.ubp.mu |

Technical Characteristics

Blocks of common aggregates (Basalt)		Minimum crushing strength (refer to technical notes)
U Block	150 mm thickness	3.5 N/mm ²
	200 mm thickness	3.5 N/mm ²
Corner Block	150 mm thickness	3.5 N/mm ²
	200 mm thickness	3.5 N/mm ²

Uses of U Blocks and Corner Blocks

U blocks and Corner blocks of the Smart Blocks range are used for the construction of individual houses, semi-detached, cluster houses, schools, agricultural and industrial projects.

When 150mm thick blocks are used as external walls, it is not advisable to go beyond ground plus one (G+1). For taller buildings, an Engineer's advice ought to be sought.

Vertical ties are to be used when two conditions exist:

- The walls are load bearing.
- These walls are made of conventional blocks (Basalt aggregates).

Note 1: *The presence of the vertical ties is two-fold. They surround the blockwork and link the horizontal ties together, and also prevent the lifting of the concrete floor slabs at corners.*

Note 2: *When the roof is not made of concrete, it must be ensured that the structure is adequately laterally braced against wind forces.*

Reinforcement Principles

The French DTU 20.1 – Eurocode (Non-seismic zone) stipulates minimas that can be applied 'as-is', when 200mm blocks are used as perimeter walls.

When **150mm blocks** are used as perimeter walls (which is the most common practice in Mauritius) the following minimas are to be used:

- Steel of vertical ties in the corners and recessed angles: 2Y12.
- Doors and windows jambs: 1Y10 minimum, which can be increased to 2Y10 or even 2Y12 if needed structurally.
- The minimum area of steel of inclined ties, along gable walls, is similar to those of vertical or horizontal ties, i.e. 2Y10 minimum with a lap length of 50 Ø.

Reinforcing of Ties

The re-bars of each vertical tie are anchored in the foundations and the floors, right up to the roof, finishing in an L shape, for proper anchorage and bonding (Figure 3).

- The horizontal ties resting on top of the load bearing blockwork are reinforced by 2Y10 minimum (Figure 4).
- The reinforcing bars in lintols vary according to the span and applied load. (Up to 1.4m 1Y12 is normally sufficient) for bigger span, an Engineer's advice ought to be sought.
- The minimum bearing of an isolated lintol is 200mm each side.

Laying of Blocks

The block walls are erected on a standard strip footing.

- The first row of blocks is laid on a mortar bed and set level.
- The mortar must be of a plastic mix in order to facilitate the placing of the blocks.
- The blocks forming the angles and the jambs of doors and windows are placed first. This will help to set a perfect alignment for the intermediate blocks.
- The blocks of the first row which are to receive the vertical ties are precut at their base in order to facilitate the cleaning of construction debris in the bottom block and to allow the tying of the re-bars which are to be placed in the open cell before concreting (Figure 3).

After having completed the first row, the angles and jambs are erected on 5 rows maximum for a 150mm block, and 6 rows maximum for a 200mm block.

- The control line of the angles is used to set level each row with the help of a spirit level.
- The inside part of the open cell is cleaned, while the mortar is still fresh in order to facilitate the casting of the concrete at a later stage.
- It is good practice to humidify the cells prior to concreting.

Using Accessory Blocks of the Smart Blocks Range to Facilitate the Creation of Specific Ties

U Blocks are used as permanent shuttering to construct:

- Horizontal ties on top of load bearing block walls (Figures 4 & 8).
- Lintols over doors and windows (Figure 5).
- Window sills (Figure 6).

Corner Blocks are used to create:

- Perfect right angles (90° Angles) (Figure 1).
- Doors and windows jambs (Figures 2 & 7).

The coping tiles (panelles) are used on the edge of perimeter walls at slab level in order to:

- Eliminate traditional shuttering (Figure 4).
- Provide the plaster of the external wall a homogenous support that will minimize the risk of the appearance of shrinkage cracks at junction of materials of different thermal values. It is good practice to reinforce the plaster locally at this point (Figure 9).
- The thickness of the coping tiles must not be more than 1/3 of the supporting wall, plaster excluded, in order to allow for the concrete slab to rest on a width equal to a minimum of 2/3 of the wall (Figure 9).

Casting the Jambs and the Vertical Tiles

- The concrete cast in situ has a cement content of 350 Kg/m³ and the aggregate used is a 12mm (10-14) max. An aggregate size of 10mm (6-10) is generally advisable in order to have a flowing and a more workable concrete.
- The casting is made on a maximum height of 6 blocks, with the help of a bucket and compacted by a steel bar.
- The cast stops at the middle of the last block, to allow for a good splicing with the next pour.
- The cover to the main bars is 20mm minimum inside the open cell.

IMPORTANT

The use of these Smart Blocks does not eliminate the need for columns and traditional beams when the latter are structurally needed.

For any further information please contact an Engineer or the Research & Development department of the UBP.

Report of the University of Mauritius

In a view to provide reliable information on the engineering applications and advantages of the U and corner blocks, the UBP requested the Department of Civil Engineering of the University of Mauritius to carry out a technical, cost and sustainability assessment on the use of corner and U blocks in typical residential houses in Mauritius. The model dwelling is a one storey load bearing structure comprising of load bearing concrete cellular blocks and reinforced concrete foundations, columns beams and solid slab and having an average floor area of 150m². It consists of three bedrooms, a kitchen, a bathroom, toilet, a veranda and a garage. The assessment has shown that the use of Corner and U blocks of 150mm width allows a saving in the amount of concrete, reinforcement and formwork used while providing the same structural soundness as the conventional reinforced concrete structures. A saving of about 10% in the cost of a typical residential building (on a 'shell and core' basis) and a reduction of the carbon footprint by about 7 tons of carbon dioxide are achieved. In addition, works of a better quality and having shorter project durations are other advantages.

**Prof. (Dr.) Toolseeram Ramjeawon
&**

Mr. A. Cadessa RPEM. - MIES

Dept. of Civil Engineering
Faculty of Engineering
University of Mauritius

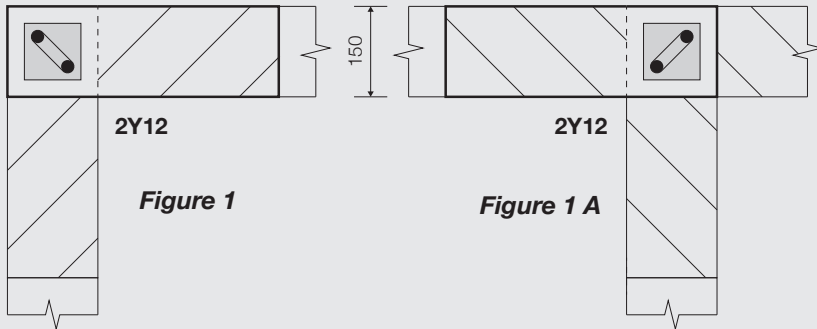
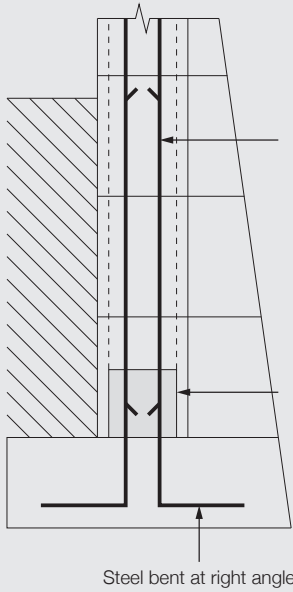

Figure 1

Figure 1 A

Vertical Ties



Overlapping of steel
50 Ø minimum

Figure 3

The opening allows the
cleaning of the block
& also the tying of
the splice bars

Steel bent at right angle

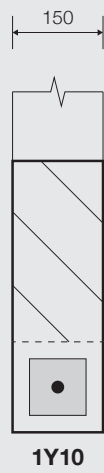

Figure 2

1Y10

Horizontal Ties

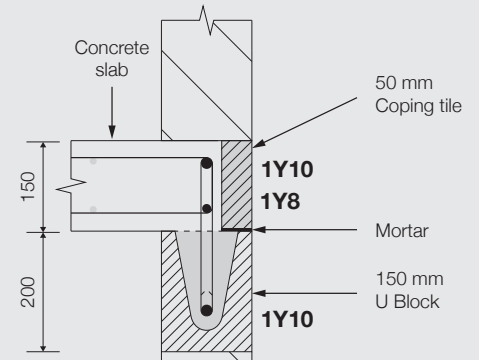

Figure 4

Lintol
Max span 1.4 m

Figure 5

1Y12

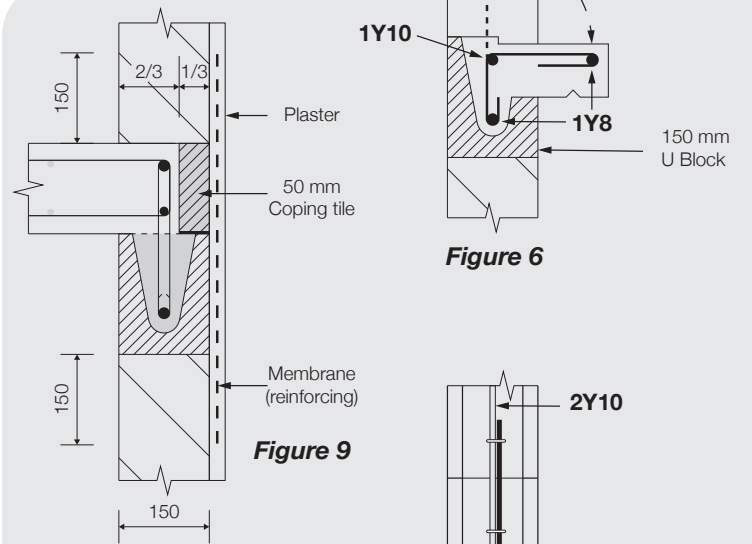

Figure 6

Figure 9

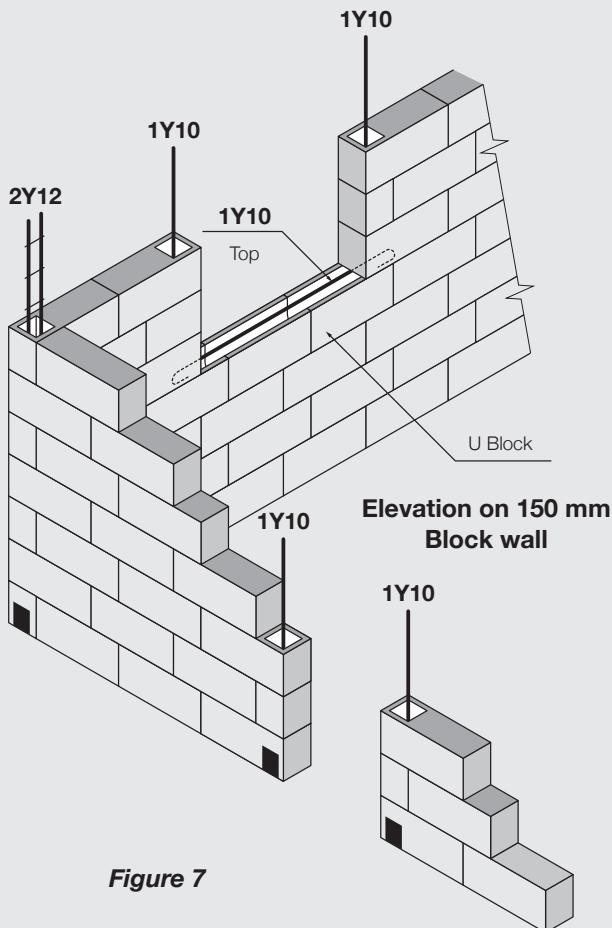

Figure 7

**Elevation on 150 mm
Block wall**

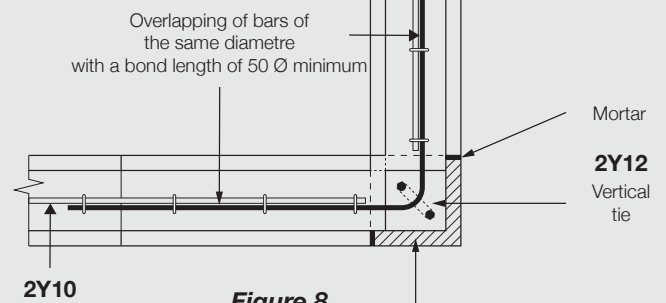

Figure 8

Cut off piece of an open cell
of a 150 mm Corner Block
to form shuttering of the corner angle

DTA - March 2018
(English version)



Bâtir pour la vie

Head Office
Trianon, Quatre Bornes
T: 454 1964
F: 454 8043
Call free: 800 1122

www.ubp.mu